

NOTE: FAILURE TO FOLLOW THESE INSTRUCTIONS WILL VOID THE WARRANTY.

UNPACKING AND MOUNTING THE REEL

1. Inspect the reel for shipping damage.
2. Check the wiring kit against the parts list.
3. Fasten the reel frame securely to a level surface.
4. Turn the reel discs by hand. The spool should turn freely. If it binds, adjust the self-aligning bearings.
5. Check motor voltage matches the supply voltage.

CONNECTING THE INLET

1. Threaded-type swivel joint inlets must be connected to the fluid supply by a **flexible connector** or the Hannay Warranty will be void.
2. Victaulic-type inlet connections must be carefully aligned. Two victaulic connections, correctly installed, will normally allow adequate flexibility for smooth rotation.
3. Install a union fitting as near as possible to the swivel joint so the joint can be easily removed for servicing.

WIRING THE REEL

1. Certain accessories have been provided to wire your reel (see following pages). You will, however, need to provide a few additional materials:
 - Insulated Cable (see motor nameplate for amperage)
 - Various Insulated Ring Terminal and Wire Nut Connectors (installation specific)
 - Circuit Breaker (see chart for amperage ratings)
 - Ground Strap for Reel - Vapor-proof Conduit (optional)
2. Follow the appropriate wiring diagram on the following pages to make the necessary connections. Check all ground connections before using motor.

NOTE: #6 AWG wire should be sufficient in most installations to prevent significant voltage drop. However, you may choose to use heavier #4 AWG if the total circuit length is unusually long.
3. The solenoid (12V DC or 24V DC motors only) should be mounted as close as possible to the battery and/or starter and grounded securely. A circuit breaker **MUST** be wired into the circuit between the solenoid and battery.
4. The motor rotation can be reversed by interchanging the motor leads.
5. If you choose to use vapor-proof conduit between the solenoid and motor, then seal the open end of the conduit with a sealing compound and wrap with electrical tape.

6. A ground strap must be securely fastened between the reel frame and a grounded part of the vehicle body. The motor ground lead must be directly bonded to the chassis. Do **NOT** rely on the reel structure for grounding. For explosion proof applications, the ground lead must be run to, and bonded to, the chassis in a non hazardous location such as the engine compartment of the vehicle.
7. Tape all connections and check each one to make sure they are secure.

CONNECTING THE HOSE

1. Do **NOT** attach the hose until the reel has been installed and wired.
2. Charge the hose before winding it on the reel. This will protect the drum from excessive pressure.
3. If reel has flanged outlet riser: Remove the entire riser from the hub. Be careful not to damage the gasket/o-ring. Apply thread compound to all threads and bushings. Thread the hose onto the outlet riser. Replace the riser and tighten securely, making sure the gasket/o-ring is seated properly. If reel does **NOT** have flanged riser: The riser can't be removed, so you will need to thread the hose directly onto the riser.
4. Wind the hose onto the reel (either electrically or with the hand crank).

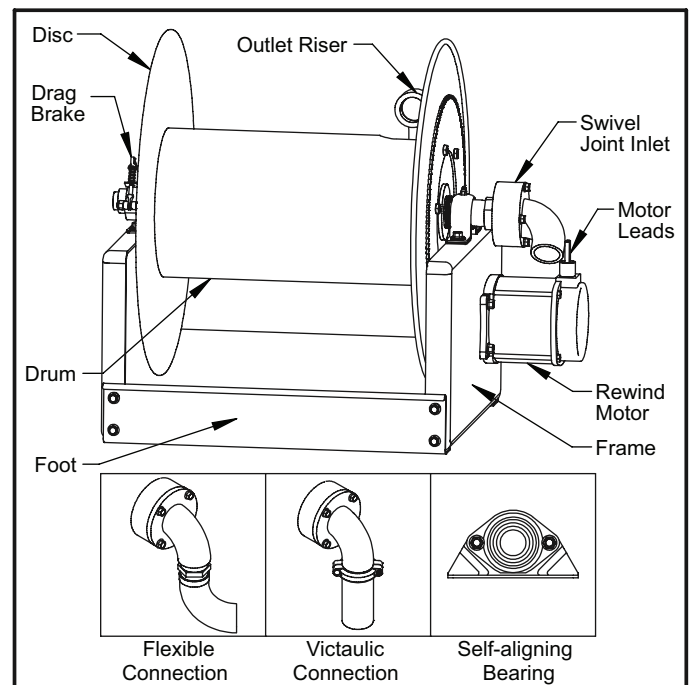

WARNING: BEFORE WIRING MOTOR BE SURE TO VERIFY THE MOTOR VOLTAGE LISTED ON THE MOTOR TAG MATCHES THE SUPPLY VOLTAGE.

WARNING: BEFORE WIRING MOTOR BE SURE TO VERIFY THE MOTOR VOLTAGE LISTED ON THE MOTOR TAG MATCHES THE SUPPLY VOLTAGE.

E or EP Reels with either a 12V DC Motor OR a 24V DC Motor

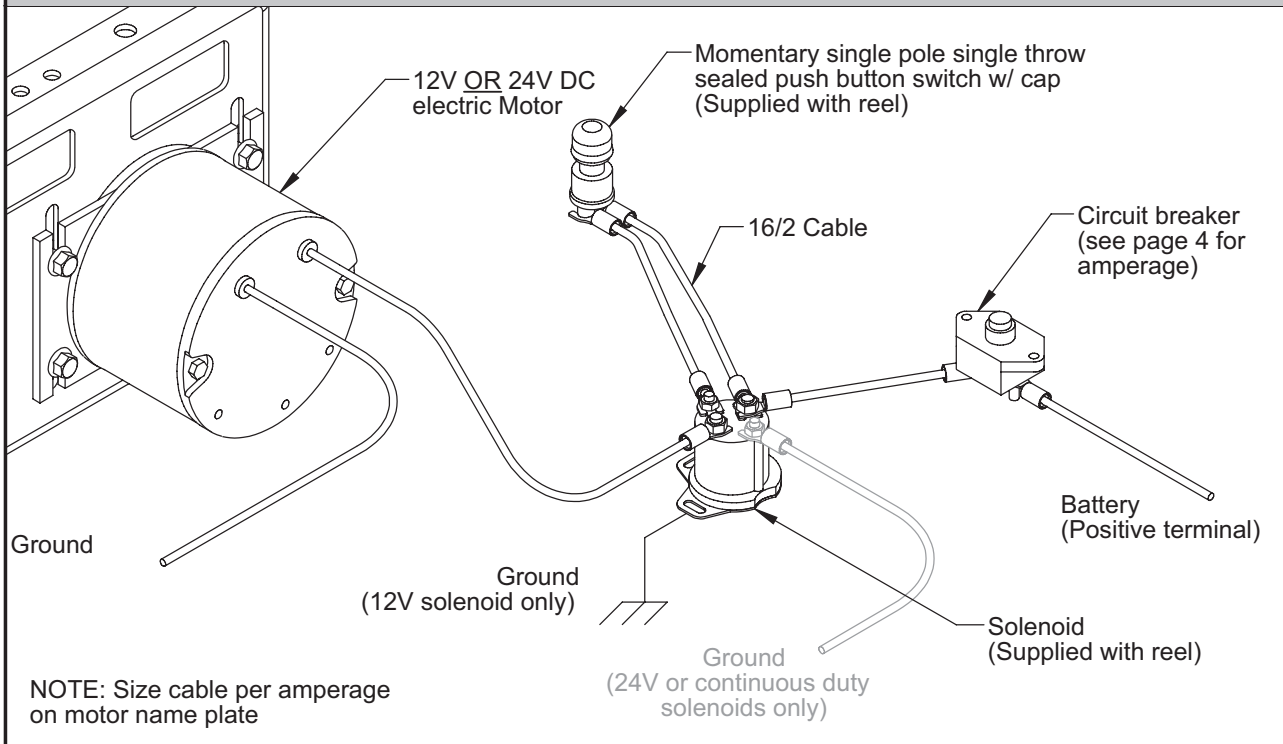

WARNING: BEFORE WIRING MOTOR BE SURE TO VERIFY THE MOTOR VOLTAGE LISTED ON THE MOTOR TAG MATCHES THE SUPPLY VOLTAGE.

E, EP or EPJ Reels with either a 115V AC Motor OR a 230V AC Motor

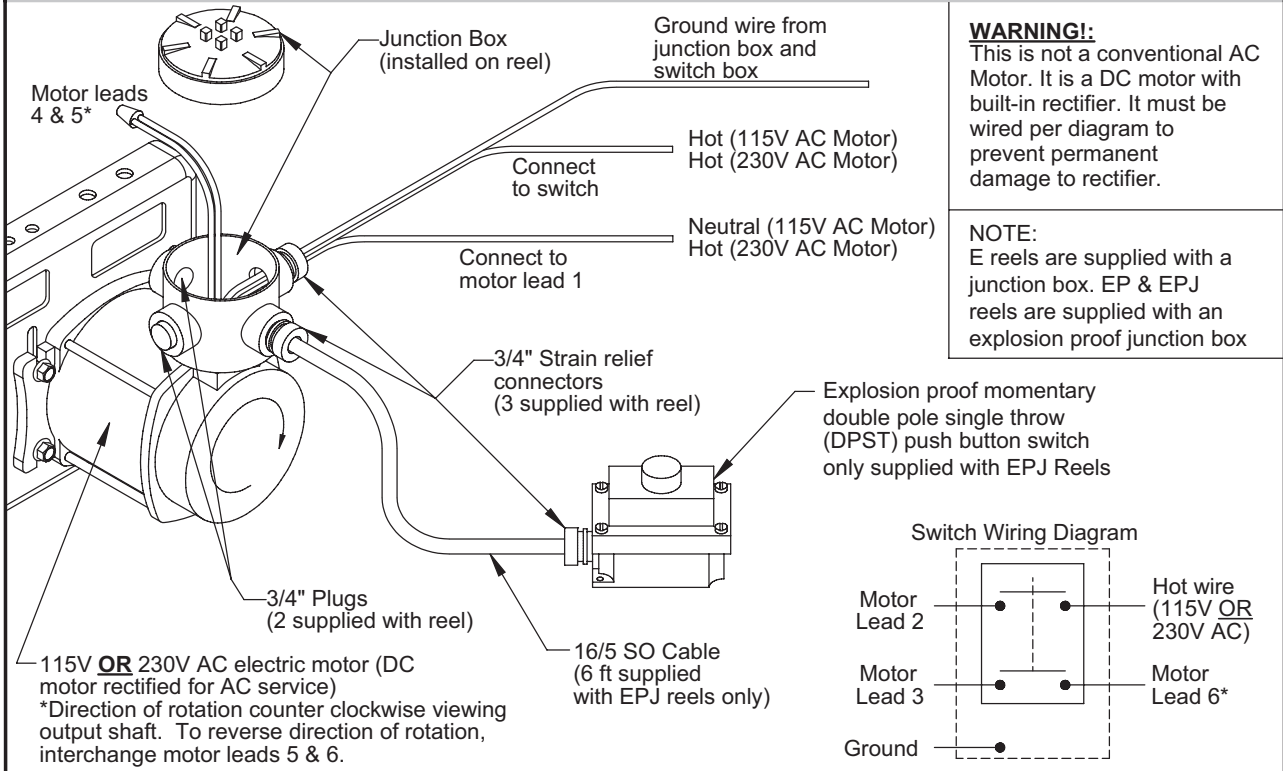

NOTE: USING A 115V MOTOR ON A 230V CIRCUIT WILL VOID WARRANTY. BE SURE TO VERIFY THE MOTOR VOLTAGE LISTED ON THE MOTOR TAG MATCHES THE SUPPLY VOLTAGE.

WARNING: BEFORE WIRING MOTOR BE SURE TO VERIFY THE MOTOR VOLTAGE LISTED ON THE MOTOR TAG MATCHES THE SUPPLY VOLTAGE.

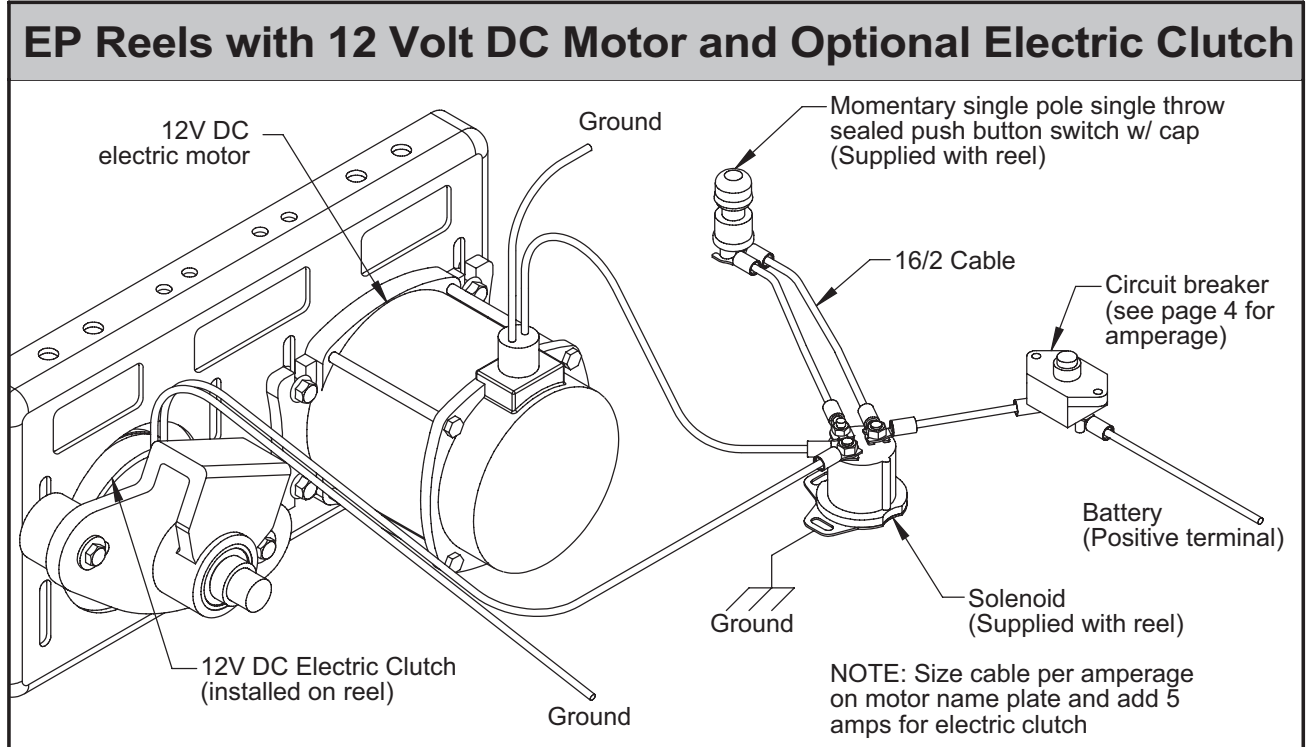

WARNING: BEFORE WIRING MOTOR BE SURE TO VERIFY THE MOTOR VOLTAGE LISTED ON THE MOTOR TAG MATCHES THE SUPPLY VOLTAGE.

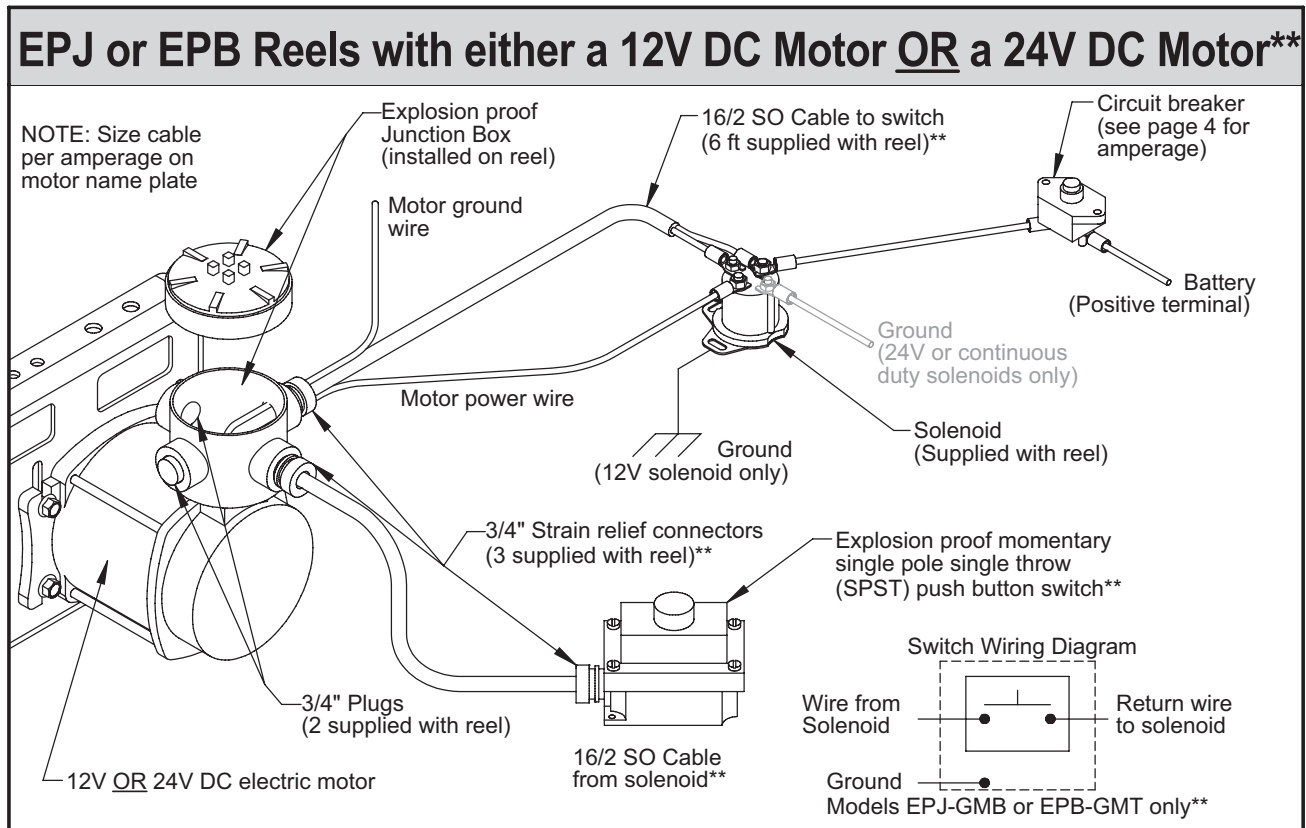

** NOTE: If reel is equipped with Hannay Guidemaster (model prefix **EPB-GMB** or **EPB-GMT**), then switch and cord are replaced with Guidemaster switch and accompanying mounting hardware. Additionally, only 2 strain relief connectors are provided. See note on wiring diagram for installing Guidemaster switch.

WARNING: BEFORE WIRING MOTOR BE SURE TO VERIFY THE MOTOR VOLTAGE LISTED ON THE MOTOR TAG MATCHES THE SUPPLY VOLTAGE.

Reels with either a 12V DC Gear Motor OR a 24V DC Gear Motor

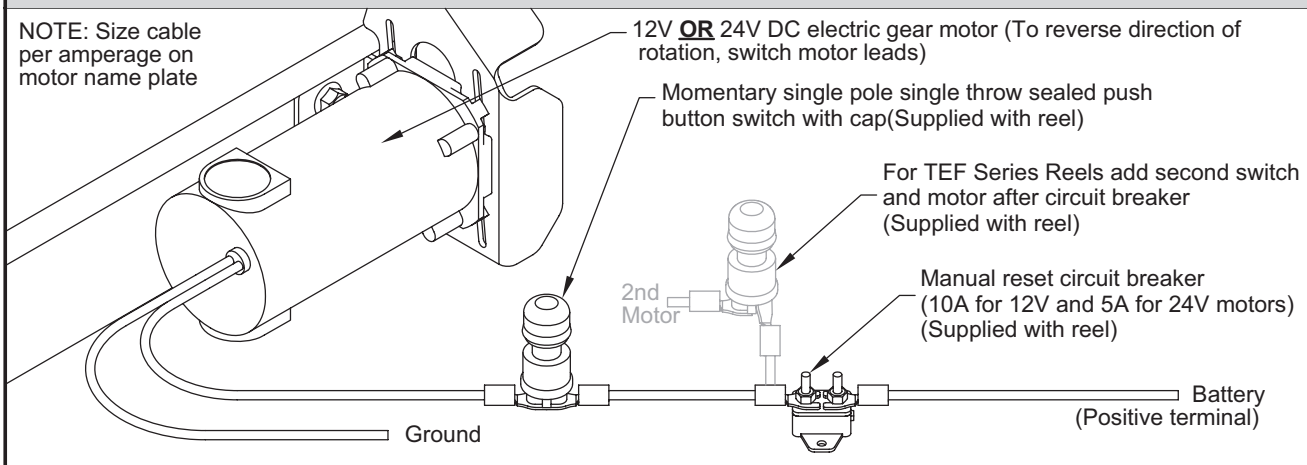

CIRCUIT BREAKER RECOMMENDATIONS

All electric rewind reels manufactured by Hannay Reels require a properly sized circuit breaker to protect the motor from a sustained overload condition. Type 3 manual reset circuit breakers are required in all Hannay motor applications.

MOUNTING – The larger-sized manual circuit breakers (50 and 70 Amp) sold by Hannay Reels can be purchased with a convenient mounting bracket. Mount the breaker away from any heat source such as an exhaust manifold or radiator. Since this style of breaker must be manually reset if tripped, it should also be mounted in a location convenient to the end user.

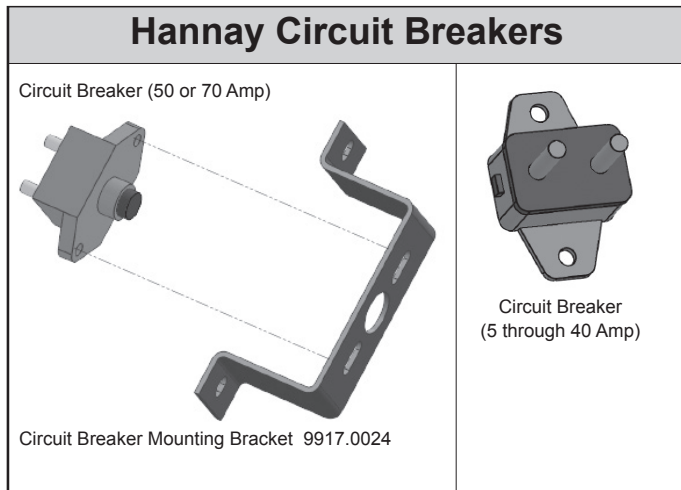

With the smaller manual reset circuit breakers (5 through 40 Amp), no mounting bracket is necessary since there are already mounting tabs provided on the circuit breaker itself.

AMPERAGE RATING – The goal in choosing an appropriately sized circuit breaker is to choose a breaker that will open the circuit in a short period of time (ideally in less than 30 seconds) when the reel motor is stalled, but not so quickly that ‘nuisance trips’ occur. Be aware that ambient temperature can cause trip times to vary.

The chart below shows recommended circuit breaker sizes to use with the motors used on Hannay-manufactured reels.

Hannay Motor Model	Wire Sizes	Circuit Breaker Size	Circuit Breaker Part Number	Mtg. Bracket Part Number
Bodine 550 Gear Motor (12V)	16 AWG	10 Amp	9917.0018	Included
TEF Series Gear Motor (12V)	16 AWG	10 Amp	9917.0018	Included
AN250 (12V)	10 AWG	15 Amp	9917.0019	Included
AN239 (12V)	10 AWG	25 Amp	9917.0171	Included
AN227 (12V)	10 AWG	40 Amp	9917.0172	Included
SX001, SX007, SX038, or SX102 (12V)	8 AWG	50 Amp	9917.0021	9917.0024
SX043, SX103, SX139, or SX153 (12V)	6 AWG	70 Amp	9917.0022	9917.0024
Bodine 990 Gear Motor (24V)	16 AWG	5 Amp	9917.0017	Included
AN248 or AN249 (24V)	10 AWG	15 Amp	9917.0019	Included
SX123, or SX145 (24V)	8 AWG	25 Amp	9917.0171	Included
AN351 or SX163 (115V AC)	16 AWG	5 Amp	-----	-----