

200 Gallon Skid

ITEM NUMBER 21-82PCXX-P550

Piston Pump

15gpm Capacity

- 200 Gallon Poly Tank
- Stainless Steel Frame with Risers
- P550 15gpm Piston Pump
- Electric Start Honda GX-390

- Easy Access Suction Filter
- Jet Agitation
- Air Gap Backflow Prevention
- 16" Lockable Lid with Tank Basket

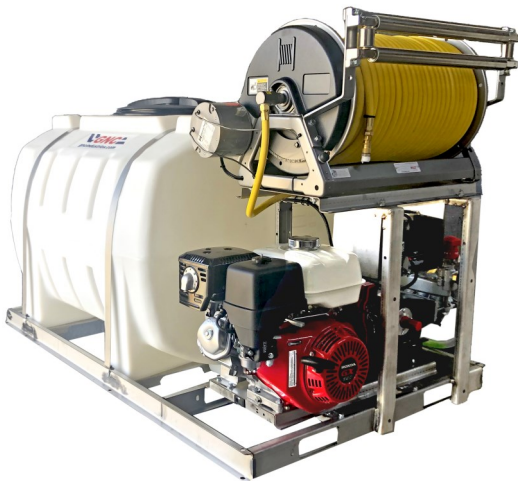

Base Sprayers	Pumps
21-82PCXX-P550	P550 Piston
21-82PCXX-KA55	Kappa 55 Diaphragm
23-990010	Upgrade P550 to Turn-Key
Reel Packages	Reel & Hose
53-HA1526-0	Hannay 18" Manual 1/2" x 300'
53-HA1526-1	Hannay 18" Manual 3/8" x 400'
53-HAE1526-0	Hannay 18" Electric 1/2" x 300'
53-HAE1526-1	Hannay 18" Electric 3/8" x 400'
HA-9939-1018	18" Roller Guides

18" Hose Reel and Hose Sold Separately

ACCESSORIES

	Sprayer Cover * 19"H x 46"L x 21"W	21-200021
	Mag-1 Do-All	11-855-00
	Mag-1 Original	11-852-00
	Mag2000. Kit	11-857-01
	Fits 3/8" Hose Fits 1/2" Hose	FT-QD38TW FT-QD12TW

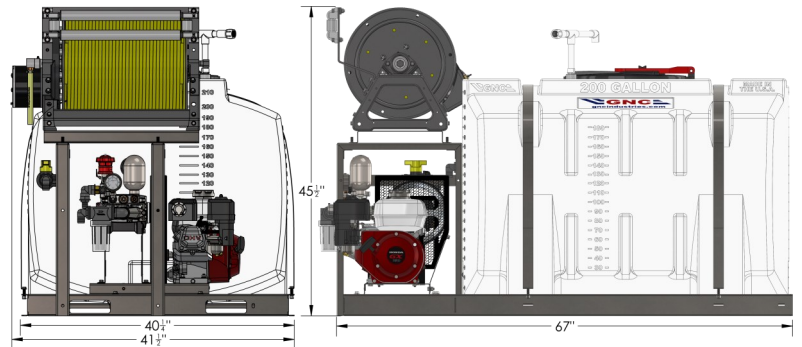

Weight

340 lbs Empty 2010 lbs Full
Approx 450 lbs Shipping