

100G PROFESSIONAL PEST CONTROL

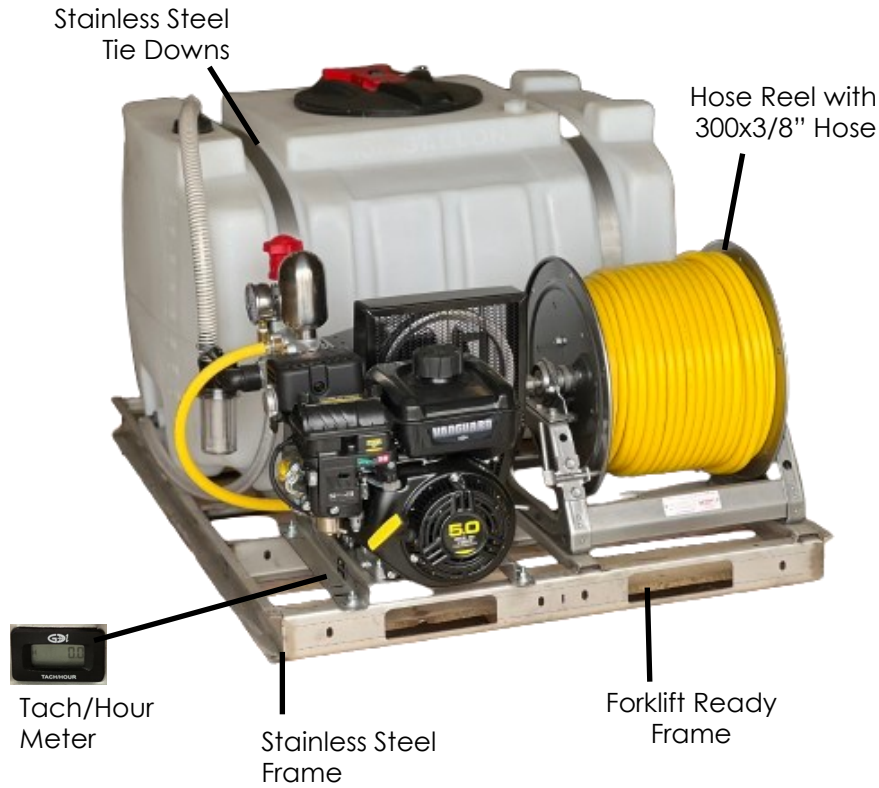

| SKU | 21-51LP96-P530 | 21-51LP86-P530 |
|-----------------------------|---|---|
| Tank Size: | 100 Gallon | 100 Gallon |
| Pump: | P530 (9GPM) Piston (0-600PSI) | P530 (9GPM) Piston (0-600PSI) |
| Engine: | Vanguard Manual Start | Vanguard Manual Start |
| Agitation: | Jet Agitation | Jet Agitation |
| Frame: | Stainless Steel | Stainless Steel |
| Hose Reel: | Hannay 12" Manual | Hannay 12" Electric |
| Hose: | 3/8" I.D. X 300 ft. w/Quick Disconnect | 3/8" I.D. X 300 ft. w/Quick Disconnect |
| Spray Gun: | Mag-1 Adjustable Spray Gun | Mag-1 Adjustable Spray Gun |
| Shipping Dimensions: | 63" x 49" x 41" | 63" x 49" x 41" |
| Weights | | |
| Empty | ≈ 254 lbs. | ≈ 270 lbs. |
| Full | ≈ 1,088 lbs. | ≈ 1,108 lbs. |
| Shipping | ≈ 375 lbs. | ≈ 395 lbs. |



ACCESSORIES:



| SKU | DESCRIPTION |
|--------------|-------------------------|
| HA-9939-1012 | Hose Reel Roller Guides |
| 91-MW2300 | Measuring Wheel |

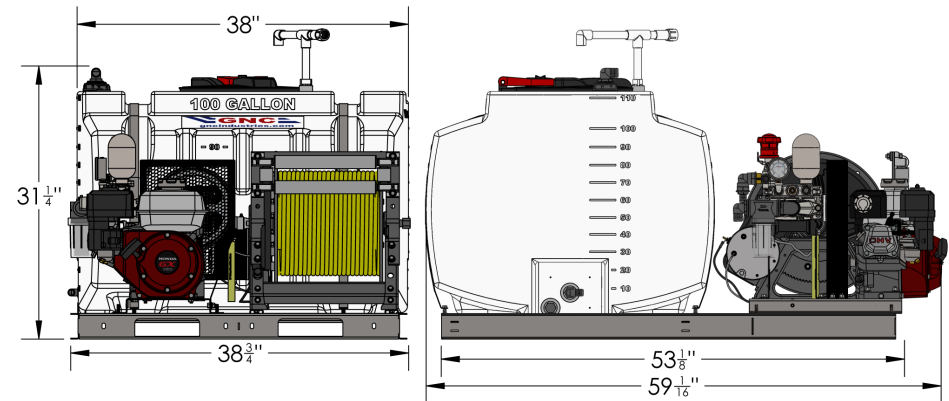

www.gncindustries.com