

200/100 Gallon Split Fiberglass Skid

ITEM NUMBER 21-82FSXX-P530

- 200/100 Gallon Split Fiberglass Tank
- Stainless Steel Frame with Risers
- P530 8gpm Piston Pump
- Manual Start Honda GX-160

Piston Pump 8gpm Capacity

- Easy Access Suction Filter
- Jet Agitation
- (2) Sight Gauges
- Air Gap Backflow Prevention
- (2) 16" Lockable Lid and Tank Basket



Base Sprayers	Pumps
21-82FSXX-P530	P530 Piston
21-82FSXX-KA43	Kappa 43 Diaphragm
24-HE55UG	Upgrade Engine to Electric Start
23-990020	P530 Upgrade to Turn-Key
Reel Packages	Reel & Hose
53-HAE1526-0	Hannay 18" Electric 1/2" x 300'
53-HAE1526-1	Hannay 18" Electric 3/8" x 400'
HA-9939-1018	18" Roller Guides
23-990005	Mechanical Agitation

18" Hose Reel and Hose Sold Separately

ACCESSORIES

	Sprayer Cover * 20.5"H x 24"L x 19"W	21-200002
	Mag-1 Do-All	11-855-00
	Mag-1 Original	11-852-00
	Mag2000. Kit	11-857-01
	Fits 3/8" Hose Fits 1/2" Hose	FT-QD38TW FT-QD12TW

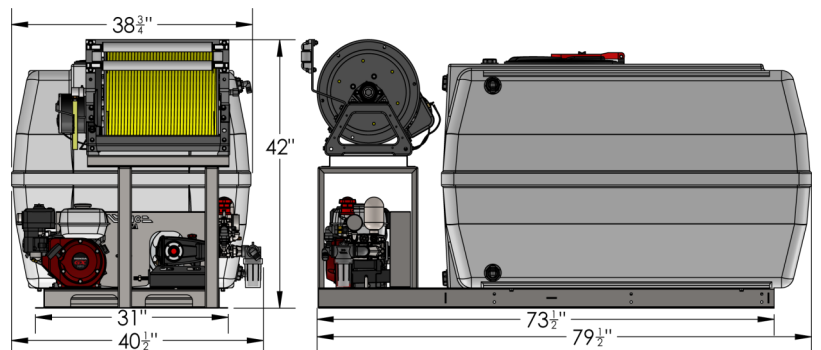

Weight

609 lbs Empty 3111 lbs Full
Approx 750 lbs Shipping
Shipping Dimensions 94" x 48" x 57"