

200/200 Split Space Saver

ITEM NUMBER 21-8CSSXX-P530

Piston Pump

8 gpm Capacity

- 200 & 200 Gal Space Saver Tanks
- Stainless Steel Frame
- P530 8gpm Piston Pump
- Manual Start Honda GX-160

- Easy Access Suction Filter
- 3-Way Valve Assembly
- Jet Agitation
- Air Gap Backflow Prevention
- 16" Lockable Lids

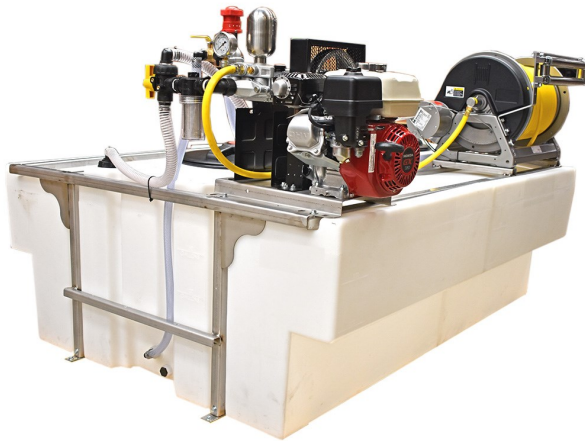

Base Sprayers	Pumps
21-8CSSXX-P530	P530 Piston
21-8CSSXX-KA43	Kappa 43 Diaphragm
23-990020	Upgrade P530 to Turn-Key
Reel Packages	Reel & Hose
53-HA1526-0	Hannay 18" Manual 1/2" x 300'
53-HA1526-1	Hannay 18" Manual 3/8" x 400'
53-HAE1526-0	Hannay 18" Electric 1/2" x 300'
53-HAE1526-1	Hannay 18" Electric 3/8" x 400'
HA-9939-1018	18" Roller Guides
FR-1200SS-FL	Fork Lift Channels

18" Hose Reel and Hose Sold Separately

ACCESSORIES

	Sprayer Cover * 20.5"H x 24"L x 19"W	21-200002
	Mag-1 Do-All	11-855-00
	Mag-1 Original	11-852-00
	Mag2000. Kit	11-857-01
	Fits 3/8" Hose Fits 1/2" Hose	FT-QD38TW FT-QD12TW

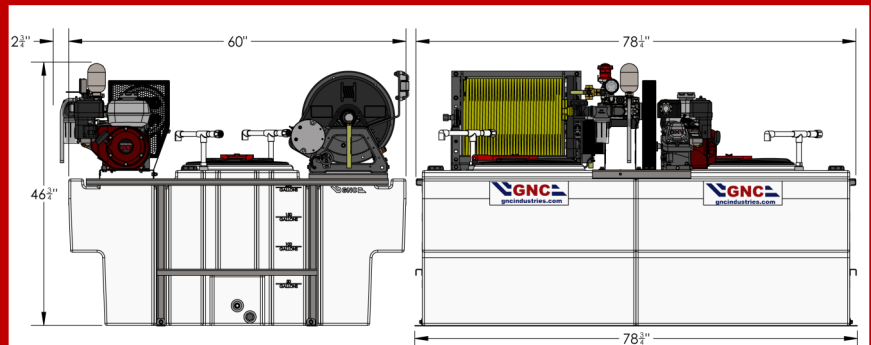

Weight

570 lbs Empty 3900 lbs Full
Approx 650 lbs Shipping